

February 3rd, 2020

Dear Employer/Cosponsor:

The **Employment Expo 2020** will be held on **Tuesday, April 7, 2020**, from **9:00 AM to 4:00 PM** at the **Kovalchick Convention and Athletic Complex** located in Indiana. Take this opportunity to showcase your company and find the right employees! You may participate in one of two ways. Enclosed are the Standard Registration and Co-Sponsorship Registration forms. Complete the form that matches your level of participation. **REGISTRATION DEADLINE IS MARCH 30, 2020.**

#### STANDARD REGISTRATION

Reserve your space and come to recruit applicants. Included are the following:

- Advertising by our team to attract qualified job seekers to this event.
- A display area with 1 table and covering, 2 folding chairs, and access to electricity if requested.
- An employer break area with refreshments for you throughout the event.

#### CO-SPONSORSHIP REGISTRATION

Reserve your space **AND** spotlight your company to job seekers. Reap all the benefits of the Standard Registration:



- Your organization will be included in newspaper promotional material.
- Your organization will be featured throughout the event on in-house media boards. The level of sponsorship will determine where job seekers will see your information.
- Red and Gold level co-sponsors will also be promoted on local radio segments (Indiana in the Morning AM 1160 and FM 101.1)

If you have any questions or need additional information, contact Kevin Lazor at 724-471-7233 or [klazor@pa.gov](mailto:klazor@pa.gov).

Sincerely,

BUSINESS SERVICE TEAM

**EMPLOYMENT EXPO 2020**  
**Standard Registration**  
*Due no later than March 30, 2020*

Complete this form for a **Standard Registration** and submit it along with payment of \$120.00 made payable to “**St. Pier Group**”. **Payment must be received no later than March 30, EMPLOYMENT EXPO 2020 - ATTN: Carrie Rayko** [CRayko@rendabroadcasting.com](mailto:CRayko@rendabroadcasting.com)

Company Name: \_\_\_\_\_ Phone: \_\_\_\_\_  
Address: \_\_\_\_\_ City: \_\_\_\_\_ State: \_\_\_\_\_ Zip: \_\_\_\_\_  
Contact Person for this Event: \_\_\_\_\_  
Contact Person’s Email: \_\_\_\_\_

Are you willing to participate in a 15-minute panel discussion on one of the following topics to Indiana County students? Questions will be provided to you prior to the event to help you prepare for the discussion. **If Yes, please email Kristin Curci at <kcurci@homercenter.org**

Please list your primary industry: \_\_\_\_\_

Do you require electricity?.....  Yes  No

Would you like to be contacted prior to the event regarding FREE posting of your job openings?.....  Yes  No

Are you willing to have your company’s contact information listed on a job shadowing database that Indiana County students and educators can access to seek out half-day or full-day job shadowing experiences?.....  Yes  No

Are there any special accommodations that you need prior to or during the event? (If yes, please specify below.) .....  Yes  No

\_\_\_\_\_  
\_\_\_\_\_

**No Refunds for Cancellations Received after March 30, 2020**

**EMPLOYMENT EXPO 2020**  
**Co-Sponsorship Registration**  
*Due no later than March 30, 2020*

Complete this form for a **Co-Sponsorship Registration** and submit it along with your advertisement(s) (if needed), and payment made payable to St. Pier Group." **Payment and advertisement(s) must be received no later than March 30, 2020** at the following address:  
**St. Pier Group ATTN: Employment Expo 2020, 840 Philadelphia Street Suite 100 Indiana, PA 15701**

**GOLD CO-SPONSORSHIP REGISTRATION: \$800.00**

- Listing in Newspaper Ad
- Promoted on Radio Segment
- Employer Provided Ad Displayed on Arena Side Boards on Event Day
- Employer Provided Ad Displayed on Arena Lobby TV's and Main Board on Event Day
- Name Listed on Arena Aux Board on Event Day  
*(See Advertising Specifications)*
- Business included in all on air commercials promoting the event across our network of 4 radio station
- Business Logo on radio stations website 's Employment Expo 2020 page
- 75 :30 commercial messages to air on your choice of radio station prior to May 30, 2020

**RED CO-SPONSORSHIP REGISTRATION: \$500.00**

- Listing in Newspaper Ad
- Promoted on Radio Segment
- Name listed on Arena Side Boards on Event Day
- Employer Provided Ad on Arena Lobby TV's on Event Day
- Employer Provided Ad on Main Board on Event Day  
*(See Advertising Specifications)*
- Business Logo on radio stations website's Employment Expo 2020 page
- Business included in all on air commercials promoting the event across our network of 4 radio station

**WHITE CO-SPONSORSHIP REGISTRATION: \$250.00**

- Listing in Newspaper Ad
- Name Listed on Arena Side Boards on Event Day
- Name Listed on Arena Lobby TV's on Event Day
- Listing on radio stations website's Employment Expo 2020 page
- Business included in all on air commercials promoting the event across our network of 4 radio station

**BLUE CO-SPONSORSHIP REGISTRATION: \$150.00**

- Listing in Newspaper Ad
- Name Listed on Arena Side Boards on Event Day
- Listing on radio stations website Employment Expo 2020 page

Company Name: \_\_\_\_\_ Phone: \_\_\_\_\_

Address: \_\_\_\_\_ City: \_\_\_\_\_ State: \_\_\_\_\_ Zip: \_\_\_\_\_

Contact Person for this Event: \_\_\_\_\_ Email: \_\_\_\_\_

Are you willing to participate in a 15-minute panel discussion on one of the following topics to Indiana County students? (check next to topic if yes) Questions will be provided to you prior to the event to help you prepare for the discussion. **If Yes, please email Kristin Curci at [kcurci@homercenter.org](mailto:kcurci@homercenter.org)** Please list your primary industry: \_\_\_\_\_

**Red & Gold Co-Sponsorship Only**

Contact Person for Advertisement: \_\_\_\_\_ Email: \_\_\_\_\_

- Do you require electricity?.....  Yes  No
- Would you like to be contacted prior to the event regarding FREE posting of your job openings? .....  Yes  No
- Are there any special accommodations that you need prior to or during the event? *(If yes, please specify below.)*.....  Yes  No

No Refunds for Cancellations received after March 30, 2020

# Employment Expo 2020 Advertising Specifications

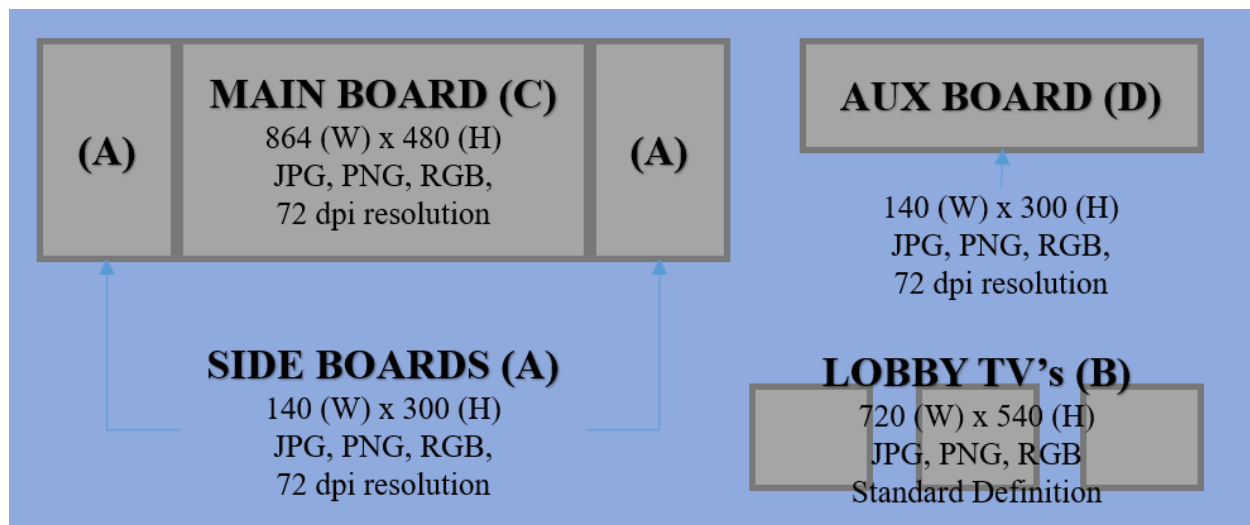

## GOLD CO-SPONSORSHIP REGISTRATION

### Two (2) Advertisements Needed

- Name (text only) displayed on **Aux Board (D)**, scrolling through the duration of the event.
- **Advertisement** displayed on **Side Boards (A)**, scrolling throughout the duration of the event.
- **Advertisement** displayed on **3 Lobby TV's (B)**, scrolling throughout the duration of the event.
- **Advertisement** displayed on **Main Board (C)**, scrolling throughout the duration of the event.
- **Submit one (1) ad** adhering to specifications identified for (A) in above diagram.
- **Submit one (1) ad** adhering to specifications identified for (C) in above diagram.

## RED CO-SPONSORSHIP REGISTRATION

### One (1) Advertisement Needed

- Name (text only) listed on **Side Boards (A)**, scrolling throughout the duration of the event.
- **Advertisement** displayed on **3 Lobby TV's (B)**, scrolling throughout the duration of the event.
- **Advertisement** displayed on **Main Board (C)**, scrolling throughout the duration of the event.
- **Submit one (1) ad** adhering to specifications identified for (C) in above diagram.

## WHITE CO-SPONSORSHIP REGISTRATION

### No Additional Material Needed

- Name (text only) listed on **Side Boards (A)**, scrolling throughout the duration of the event.
- Name (text only) listed on **Lobby TV's (B)**, scrolling throughout the duration of the event.

## BLUE CO-SPONSORSHIP REGISTRATION

### No Additional Material Needed

- Name (text only) listed on **Side Boards (A)**, scrolling throughout the duration of the event.

- ▶ Advertisements must be submitted to Carrie Rayko at [CRayko@rendabroadcasting.com](mailto:CRayko@rendabroadcasting.com) no later than **March 30, 2020**. Employers assume responsibility for proofing and accuracy of information on advertisements.
- ▶ Questions regarding advertisements may be directed to [CRayko@rendabroadcasting.com](mailto:CRayko@rendabroadcasting.com)